



佛山市国星光电股份有限公司

FOSHAN NATIONSTAR OPTOELECTRONICS CO., LTD

SPECIFICATION

Customer		Product	TOP LED
Customer No.		Type	FM-3528BK-470M

APPROVED SIGNATURES

APPROVED SIGNATURES			



Add: NO.18 South Huabao Rd,Foshan,Guangdong,China

Tel: 086-0757-83985604,83985605,83985607

Fax: 086-0757-82100221,82100223

Zip: 528000

<http://www.nationstar.com>

Research & Development Center		
APPROVE	CHECK	DRAW
Release Date: 2009-10-16		

FM-3528BK-470M Top Light Emitting Diode

Technical Data Sheet

This product is generally used as indicator and luminary for electronic equipment such as dashboard and signal Led board. And it also be widely used for indoor and outdoor decorative lighting.

Features:

- Material: Blue-InGaN
- Wide Viewing Angle
- Reflow Solderable
- High Luminous Intensity and Low Power Dissipation
- Good Reliability and Long Life
- Complied With RoHS Directive

Catalogue

Electrical Characteristics	2
Typical Characteristic Curves	3
Reliability Test Items And Conditions	4
Outline Dimensions	5
Packaging	6
Guideline for Soldering	8
Precautions	9

The Specifications of the product may be modified for improvement without notice.

Electrical Characteristics

✧ Absolute Maximum Ratings (Temperature=25°C):

Parameter	Symbol	Rating	Unit
Forward Current	I_F	25 Max.	mA
Pulse Forward Current*	I_{FP}	100 Max.	mA
Reverse Voltage	V_R	5 Max.	V
Operating Temperature	T_{OPR}	-30 ~ +85	°C
Storage Temperature	T_{stg}	-40 ~ +100	°C
Power Dissipation	P_D	120 Max.	mW

* Note: Pulse width $\leq 0.1ms$, Duty $\leq 1/10^*$

✧ Electro-Optical Characteristics (Temperature=25°C):

Parameter	Symbol	Condition	Min.	Typ.	Max.	Unit
Reverse Current	I_R	$V_R=5V$			50	μA
Forward Voltage	V_F	$I_F=20mA$		3.2	4.0	V
Dominant Wavelength	λ_D			470		nm
Spectrum Radiation Bandwidth	$\Delta\lambda$			30		nm
Luminous Intensity	I_V				400	mcd
View Angle	$2\theta_{1/2}$			110		deg.

Typical Characteristics Curves

Volt-Ampere Characteristics

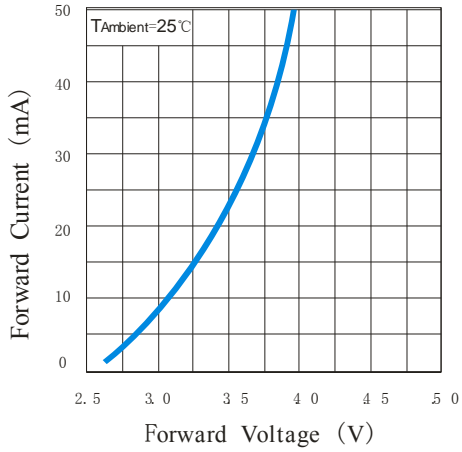

Relative Luminous Intensity VS Forward Current

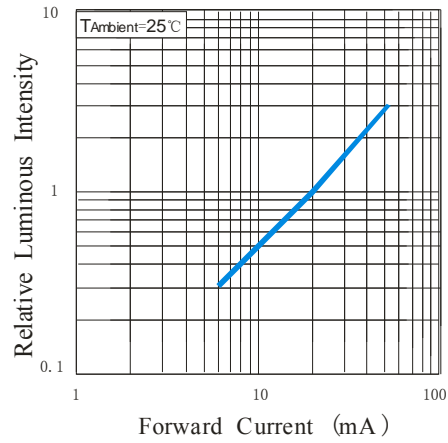

Forward Current Derating Curve

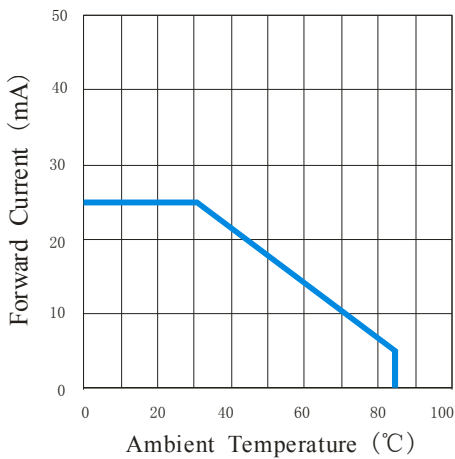

Luminous Intensity VS Ambient Temperature

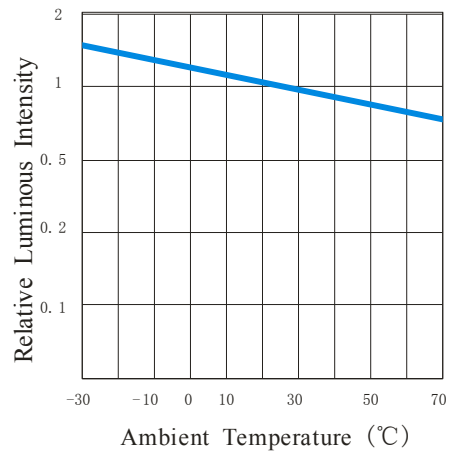

Radiation Diagram

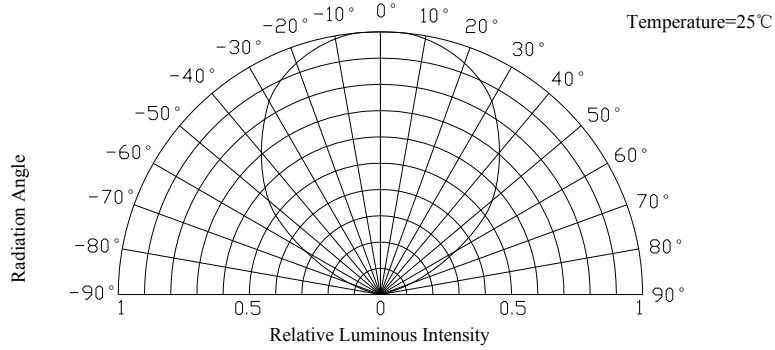

Reliability Test Items And Conditions

Test Items	Test Conditions	Quantity	Judging Criteria
Solderability	Solder Temperature: 300°C Solder Duration: (3.5±0.5) sec.	15	Solderable Area Over 95%
Thermal Shock Followed by High Temperature And High Humidity Cyclic	-40°C → 10 min. 5 Cycles ↓↑ Shift (2~3) min. 100°C → 10 min. ↓ 25°C~55°C (90%~95%) RH 2 Cycles for 48 hrs., Recover for 2 hrs.	11	C=0 & I**
Resistance For Soldering Heat	Reflow Soldering	15	C=0 & I**
DC Operating Life	1000 hrs. Forward Current: 25mA	22	C=0 & I*
High Temperature Storage	100°C → 1000 hrs.	15	C=0 & I*
High Temperature And High Humidity Cyclic	25°C~55°C (90%~95%) RH 6 Cycles for 144 hrs., Recover for 2 hrs.	11	C=0 & I*

*1 Criteria For Judging Damage

Items	Symbol	Test Conditions	Criteria For Judging Damage I*	Criteria For Judging Damage I**
Forward Voltage	V _F	I _F =20mA	≥USL×1.2	≥USL
Reverse Current	I _R	V _R =5V	≥USL×2.0	≥USL
Luminous Intensity	I _V	I _F =20mA	≤LSL×0.5	≤LSL

* USL: Upper Standard Level, LSL: Lower Standard Level *

Outline Dimensions

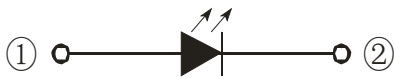
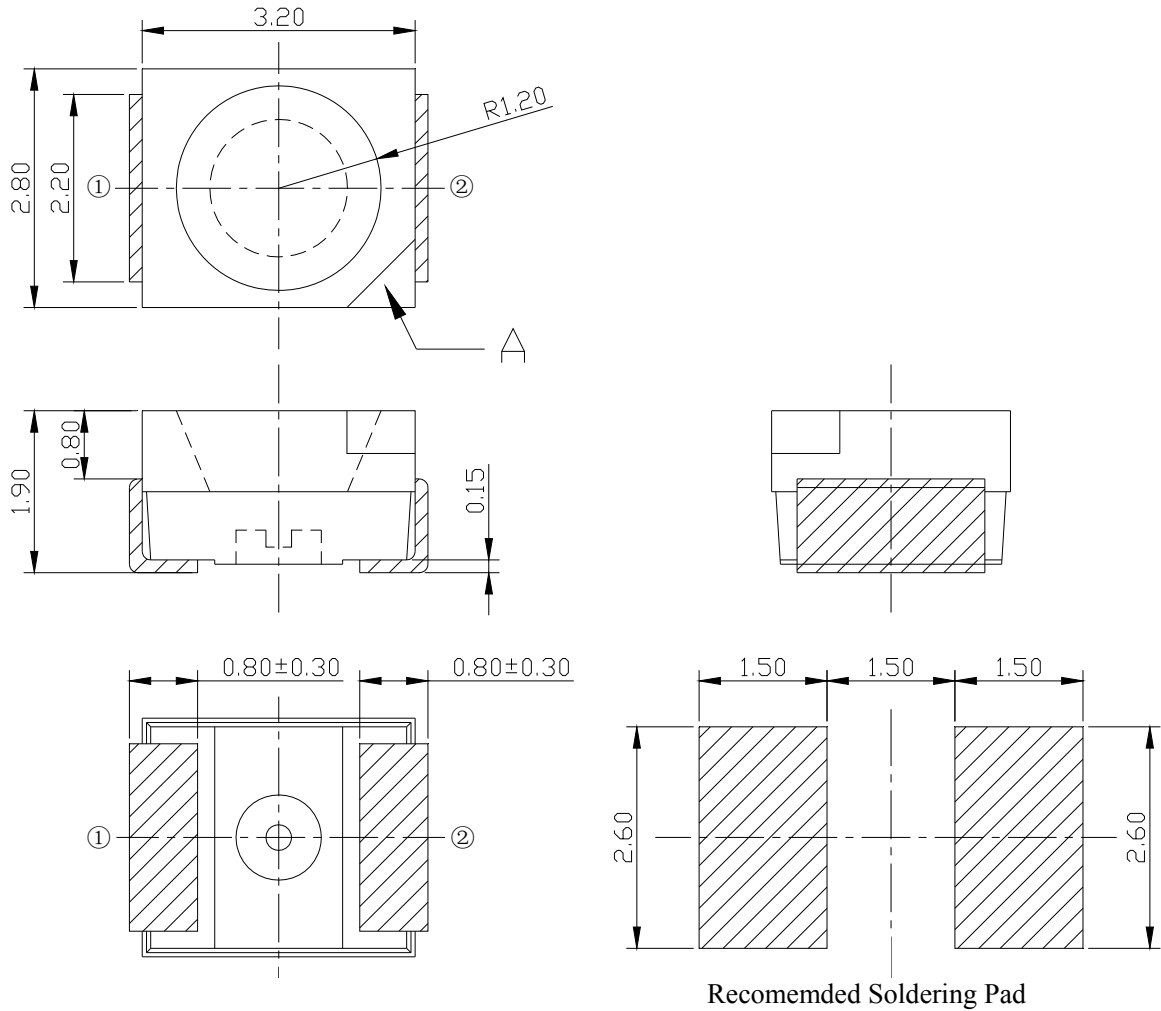

Polarity

Note:

A: Cathode Mark

All dimensions in mm.

Tolerances unless mentioned is ± 0.1 mm.

Packaging (1)

✧ Carrier Tape

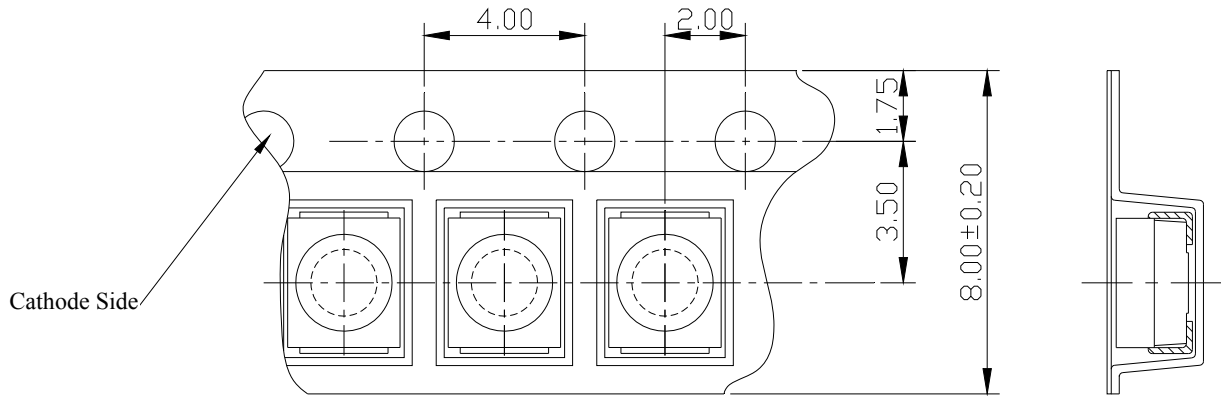

All dimensions in mm, tolerances unless mentioned is ± 0.1 mm.

✧ Details Of Carrier Tape

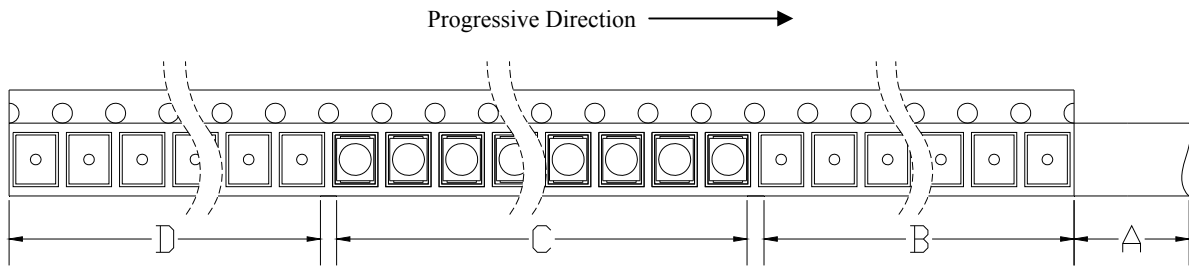

A: Top Cover Tape, 300mm; B: Leader, Empty, 200mm; C: 2000 Lamps Loaded; D: Trailer, Empty, 200mm.

✧ Reel Dimension

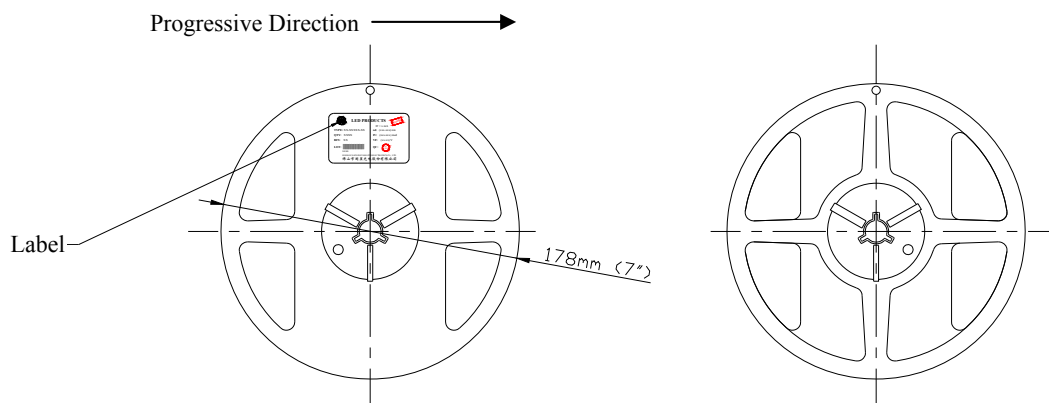

Packaging (2)

✧ Moisture Proof and Anti-Electrostatic Foil Bag

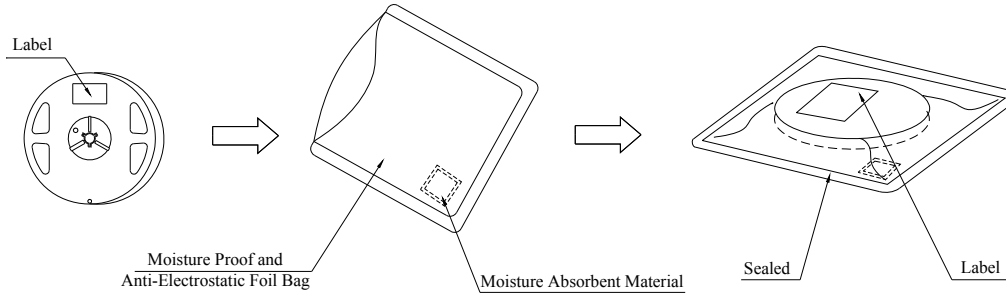

✧ Cardboard Box

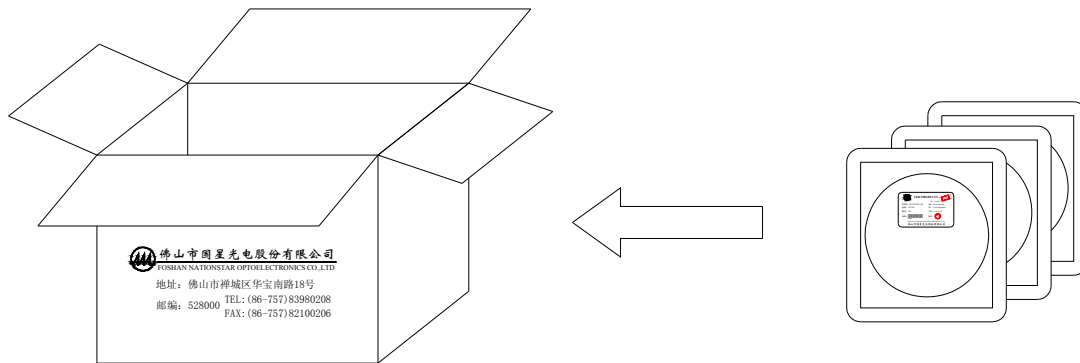

✧ Label Explanation

QTY: Quantity

BIN: Rank

LOT: Lot Number

λd : Wavelength Range

IV: Luminous Intensity Range

VF: Forward Voltage Range

IF: Testing Current





TOP LEDS RoHS

IF = x mA

TYPE: XX-XXXXXX-XX λd : (xxx-xxx) nm

QTY: XXXX IV: (xxx-xxx) mcd

BIN: XX VF: (xx-xx) V

LOT:  QC: 

XXXX

FOSHAN NATIONSTAR OPTOELECTRONICS CO., LTD
佛山市国星光电股份有限公司

Guideline for Soldering

1. Hand Soldering

A soldering iron of less than 20W is recommended to be used in Hand Soldering. Please keep the temperature of the soldering iron under 300°C while soldering. Each terminal of the LED is to go for less than 3 second and for one time only.

Be careful because the damage of the product is often started at the time of the hand soldering.

2. Reflow Soldering: Use the conditions shown in the under Profile of Pb-Free Reflow Soldering.

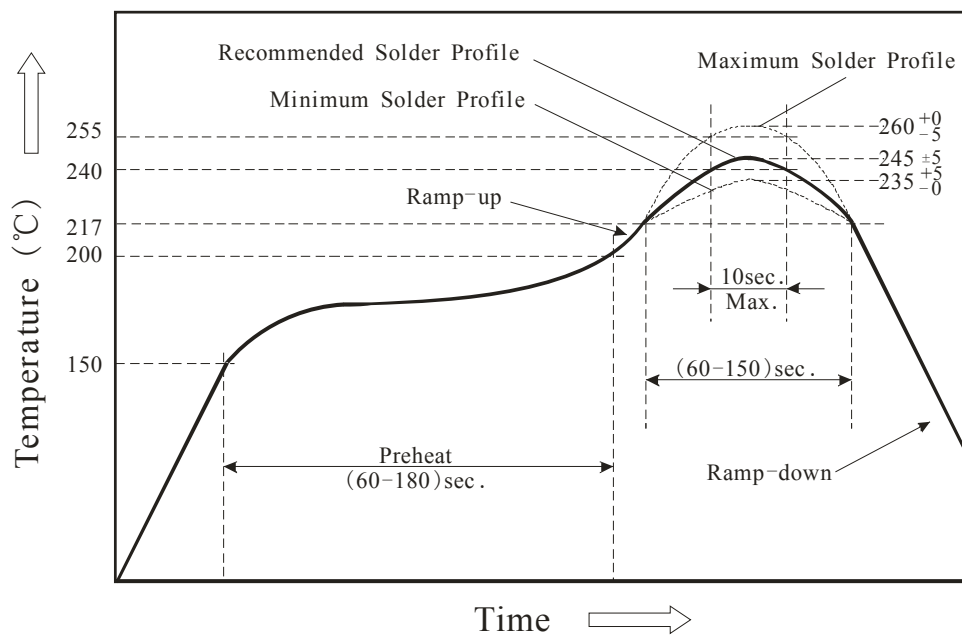

- Reflow soldering should not be done more than two times.
- Stress on the LEDs should be avoided during heating in soldering process.
- After soldering, do not deal with the product before its temperature drop down to room temperature.

3. Cleaning

It is recommended that alcohol be used as a solvent for cleaning after soldering. Cleaning is to go under 30°C for 3 minutes or 50°C for 30 seconds. When using other solvents, it should be confirmed beforehand whether the solvents will dissolve the package and the resin or not.

Ultrasonic cleaning is also an effective way for cleaning. But the influence of Ultrasonic cleaning on LED depends on factors such as ultrasonic power. Generally, the ultrasonic power should not be higher than 300W. Before cleaning, a pre-test should be done to confirm whether any damage to LEDs will occur.

Note: This general guideline may not apply to all PCB designs and configurations of all soldering equipment. The technics in practise is influenced by many factors, it should be specialized base on the PCB designs and configurations of the soldering equipment.

Precautions (1)

1. Storage

- Moisture proof and anti-electrostatic package with moisture absorbent material is used, to keep moisture to a minimum.
- Before opening the package, the product should be kept at 30°C or less and humidity less than 60% RH, and be used within a year.
- After opening the package, the product should be stored at 30°C or less and humidity less than 10%RH, and be soldered within 24 hours (1 days). It is recommended that the product be operated at the workshop condition of 30°C or less and humidity less than 60%RH.
- If the moisture absorbent material has fade away or the LEDs have exceeded the storage time, baking treatment should be performed based on the following condition: $(80 \pm 5)^{\circ}\text{C}$ for 24 hours.

2. Static Electricity

Static electricity or surge voltage damages the LEDs. Damaged LEDs will show some unusual characteristics such as the forward voltage becomes lower, or the LEDs do not light at the low current., even not light.

All devices, equipment and machinery must be properly grounded. At the same time, it is recommended that wrist bands or anti-electrostatic gloves, anti-electrostatic containers be used when dealing with the LEDs.

3. Design Consideration

In designing a circuit, the current through each LED must not exceed the absolute maximum rating specified for each LED. In the meanwhile, resistors for protection should be applied, otherwise slight voltage shift will cause big current change, burn out may happen.

It is recommended to use Circuit A which regulates the current flowing through each LED rather than Circuit B. When driving LEDs with a constant voltage in Circuit B, the current through the LEDs may vary due to the variation in Forward Voltage (V_F) of the LEDs. In the worst case, some LED may be subjected to stresses in excess of the Absolute Maximum Rating.

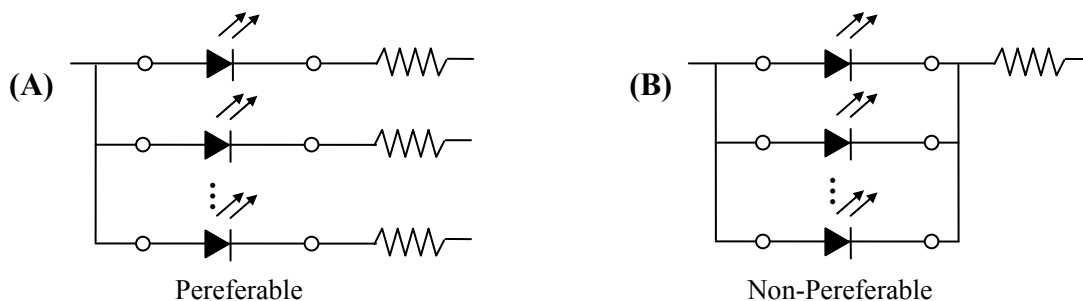

Thermal Design is paramount importance because heat generation may result in the Characteristics decline, such as brightness decreased, Color changed and so on. Please consider the heat generation of the LEDs when making the system design.

Precautions (2)

4. Others

When handling the product, touching the encapsulant with bare hands will not only contaminate its surface, but also affect on its optical characteristics. Excessive force to the encapsulant might result in catastrophic failure of the LEDs due to die breakage or wire deformation. For this reason, please do not put excessive stress on LEDs, especially when the LEDs are heated such as during Reflow Soldering.

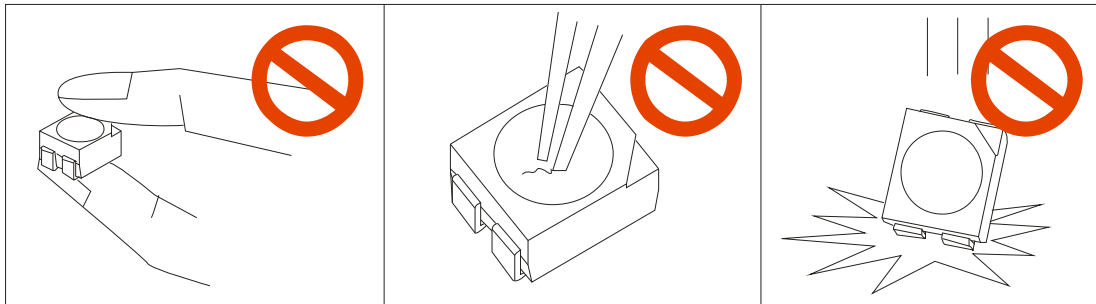

The epoxy resin of encapsulant is fragile, so please avoid scratch or friction over the epoxy resin surface. While handling the product with tweezers, do not hold by the epoxy resin, be careful.

5. Safety Advice For Human Eyes

Viewing direct to the light emitting center of the LEDs, especially those of great Luminous Intensity, will cause great hazard to human eyes. Please be careful.

Appendix: Ranking Criteria

Description Of SMD LEDs Bin Selection:

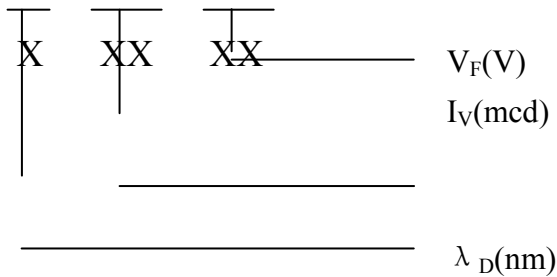

X	
λ_D (nm) * ¹	Code
466~469	
469~472	
472~475	
NO BIN	X

XX			
$I_V(mcd)$ * ²	Code	$I_V(mcd)$ * ²	Code
330~400		500~600	
400~500			
NO BIN			X X

XX			
$V_F(V)$ * ³	Code	$V_F(V)$ * ³	Code
3.0~3.2		3.4~3.6	
3.2~3.4			
NO BIN			X X

Notes: Measurement Condition: $I_F=20mA$

*1: Measurement Uncertainty : ± 0.05

*2: Measurement Uncertainty : $\pm 20\%$,



3: Measurement Uncertainty : $\pm 0.05V$