

Technical Data Sheet**TOP View LEDs****45-21UEC/XXX/TR8****Features**

- P-LCC-2 package.
- White package.
- Optical indicator.
- Wide viewing angle.
- Computable with automatic placement equipment.
- Available on tape and reel (8mm Tape).
- Pb-free

**Descriptions**

- The 45-21 series is available for orange, green, blue and yellow or other color due to the different raw material.
- Base on the package design, the device result in wide view angle.

Applications

- Backlight : LCD, switches, symbol, mobile phone and illuminated advertising.
- Display for indoor and outdoor application : Traffic...etc.
- Ideal for coupling into light guides.
- Substitution of traditional light
- Optical indicator
- General applications.

Device Selection Guide

Chip	Emitted Color	Resin Color
Material		
AlGaInP	White	Water Clear

Package Dimensions

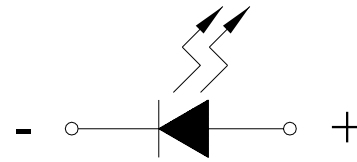
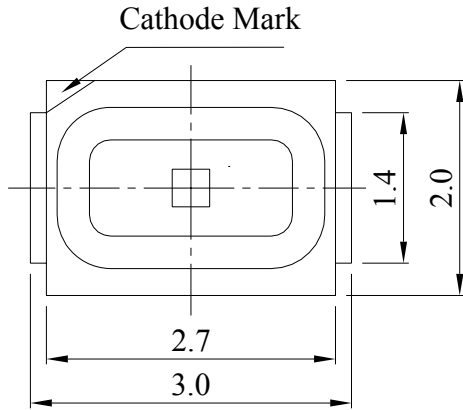

Polarity

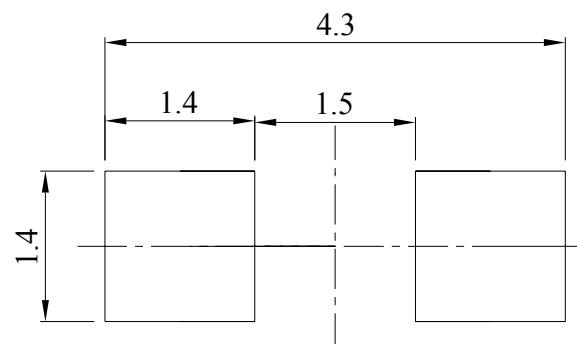
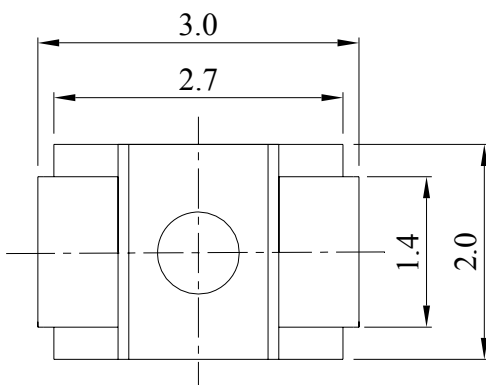
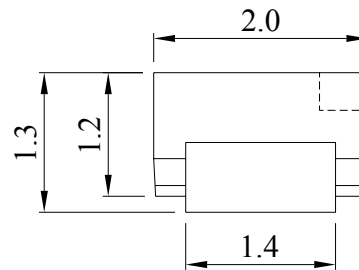
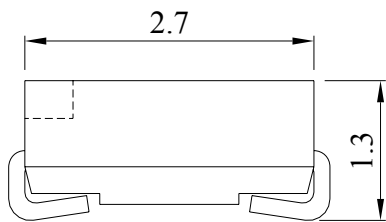

Recommended soldering pad design

Note : Tolerance of Dimension : $\pm 0.1\text{mm}$. Unit = mm

45-21UEC/XXX/TR8

Absolute Maximum Ratings (Ta=25°C)

Parameter	Symbol	Rating	Unit
Reverse Voltage	V _R	5	V
Forward Current	I _F	30	mA
Peak Forward Current (Duty 1/10 @10KHz)	I _{FP}	100	mA
Power Dissipation	P _d	110	mW
Electrostatic Discharge(HBM)	ESD	1000	V
Operating Temperature	T _{opr}	-40 ~ +85	°C
Storage Temperature	T _{stg}	-40 ~ +90	°C
Soldering Temperature	T _{sol}	Reflow Soldering : 260 °C for 10 sec. Hand Soldering : 350 °C for 3 sec.	

Note : The products are sensitive to static electricity and care must be fully taken when handling products.

Electro-Optical Characteristics (Ta=25°C)

Parameter	Symbol	Min.	Typ.	Max.	Unit	Condition
Viewing Angle	2θ _{1/2}	-----	110	-----	deg	I _F =20mA
Reverse Current	I _R	-----	-----	10	μA	V _R =5V

Bin Range of Luminous Intensity

Group	Bin Code	Min.	Max.	Unit	Conduction
7	7	750	780	mcd	I _F =20mA
	8	780	810		
	9	810	840		
	10	840	870		
	11	870	900		
9	12	900	930		
	13	930	960		
	14	960	990		
	15	990	1020		
U	16	1020	1050		
	17	1050	1080		
	18	1080	1110		
	19	1110	1140		
	20	1140	1170		
	21	1170	1200		
V	22	1200	1250		
	23	1250	1300		
	24	1300	1350		
	25	1350	1400		
W	26	1400	1450		
	27	1450	1500		
	28	1500	1550		
	29	1550	1600		
X	30	1600	1650		
	31	1650	1700		
	32	1700	1750		
	33	1750	1800		

Notes:

Tolerance of Luminous Intensity $\pm 11\%$

45-21UEC/XXX/TR8**Bin Range of Forward Voltage**

Group	Bin Code	Min.	Max.	Unit	Conduction
0	6-1	2.95	3.05	V	I _F =20mA
	6-2	3.05	3.15		
	7-1	3.15	3.25		
	7-2	3.25	3.35		
	8-1	3.35	3.45		
	8-2	3.45	3.55		
	9-1	3.55	3.65		
	9-2	3.65	3.75		

Notes:**Tolerance of Forward Voltage $\pm 0.01V$**

45-21UEC/XXX/TR8

Chromaticity Coordinates Specifications for Bin Grading (I_F=20mA)

Group	Bin Code	CIE_x	CIE_y	Bin Code	CIE_x	CIE_y	
2	1	B5-1	0.2915	0.2855	B5-3	0.2960	0.2760
			0.2870	0.2950		0.2915	0.2855
			0.2970	0.3050		0.3003	0.2950
			0.3003	0.2950		0.3035	0.2850
		B5-2	0.3003	0.2950	B5-4	0.3035	0.2850
			0.2970	0.3050		0.3003	0.2950
			0.3070	0.3150		0.3090	0.3045
			0.3090	0.3045		0.3110	0.2940
	A0-2	A0-2	0.2818	0.2715	B6-1	0.3090	0.3045
			0.2755	0.2810		0.3070	0.3150
			0.2870	0.2950		0.3185	0.3270
			0.2915	0.2855		0.3195	0.3165
		A0-4	0.2879	0.2619	B6-3	0.3110	0.2940
			0.2818	0.2715		0.3090	0.3045
			0.2915	0.2855		0.3195	0.3165
			0.2960	0.2760		0.3205	0.3060

Group	Bin Code	CIE_x	CIE_y	Group	Bin Code	CIE_x	CIE_y
3	A0-1	0.2720	0.2575	4	B6-2	0.3195	0.3165
		0.2640	0.2670			0.3185	0.3270
		0.2755	0.2810			0.3300	0.3390
		0.2818	0.2715			0.3300	0.3285
	A0-3	0.2800	0.2480		B6-4	0.3205	0.3060
		0.2720	0.2575			0.3195	0.3165
		0.2818	0.2715			0.3300	0.3285
		0.2879	0.2619			0.3300	0.3180

Notes:

The C.I.E. 1931 chromaticity diagram (Tolerance ±0.01).

45-21UEC/XXX/TR8

Chromaticity Coordinates Specifications for Bin Grading (I_F=20mA)

Group	Bin Code	CIE_x	CIE_y	Bin Code	CIE_x	CIE_y	
7	B5-1	0.2915	0.2855	A0-4	0.2879	0.2619	
		0.2870	0.2950		0.2818	0.2715	
		0.2970	0.3050		0.2915	0.2855	
		0.3003	0.2950		0.2960	0.2760	
	B5-3	0.2960	0.2760	/			
		0.2915	0.2855				
		0.3003	0.2950				
		0.3035	0.2850				
8	A0-2	0.2818	0.2715	A0-3	0.2800	0.2480	
		0.2755	0.2810		0.2720	0.2575	
		0.2870	0.2950		0.2818	0.2715	
		0.2915	0.2855		0.2879	0.2619	
	A0-4	0.2879	0.2619	/			
		0.2818	0.2715				
		0.2915	0.2855				
		0.2960	0.2760				
9	A0-1	0.2720	0.2575	A0-B	0.2720	0.2575	
		0.2640	0.2670		0.2652	0.2429	
		0.2755	0.2810		0.2733	0.2333	
		0.2818	0.2715		0.2800	0.2480	
	A0-3	0.2800	0.2480	/			
		0.2720	0.2575				
		0.2818	0.2715				
		0.2879	0.2619				

Notes:

The C.I.E. 1931 chromaticity diagram (Tolerance ±0.01)

45-21UEC/XXX/TR8

Chromaticity Coordinates Specifications for Bin Grading (I_F=20mA)

Group	Bin Code	CIE_x	CIE_y	Bin Code	CIE_x	CIE_y	
A	A0-A	0.2640	0.2670	A0-C	0.2569	0.2528	
		0.2569	0.2528		0.2498	0.2385	
		0.2652	0.2429		0.2584	0.2283	
		0.2720	0.2575		0.2652	0.2429	
	A0-B	0.2720	0.2575	A0-D	0.2652	0.2429	
		0.2652	0.2429		0.2584	0.2283	
		0.2733	0.2333		0.2666	0.2185	
		0.2800	0.2480		0.2733	0.2333	
B	A0-3	0.2800	0.2480	A0-B	0.2720	0.2575	
		0.2720	0.2575		0.2652	0.2429	
		0.2818	0.2715		0.2733	0.2333	
		0.2879	0.2619		0.2800	0.2480	
	A0-4	0.2879	0.2619	/			
		0.2818	0.2715				
		0.2915	0.2855				
		0.2960	0.2760				
C	A0-1	0.2720	0.2575	A0-2	0.2818	0.2715	
		0.2640	0.2670		0.2755	0.2810	
		0.2755	0.2810		0.2870	0.2950	
		0.2818	0.2715		0.2915	0.2855	
	A0-3	0.2800	0.2480	A0-4	0.2879	0.2619	
		0.2720	0.2575		0.2818	0.2715	
		0.2818	0.2715		0.2915	0.2855	
		0.2879	0.2619		0.2960	0.2760	

Notes:

- 1. The C.I.E. 1931 chromaticity diagram (Tolerance ±0.01).**

45-21UEC/XXX/TR8

Chromaticity Coordinates Specifications for Bin Grading (I_F=20mA)

Group	Bin Code	CIE_x	CIE_y	Bin Code	CIE_x	CIE_y
D	A0-1	0.2720	0.2575	A0-2	0.2818	0.2715
		0.2640	0.2670		0.2755	0.2810
		0.2755	0.2810		0.2870	0.2950
		0.2818	0.2715		0.2915	0.2855
	A0-3	0.2800	0.2480	A0-4	0.2879	0.2619
		0.2720	0.2575		0.2818	0.2715
		0.2818	0.2715		0.2915	0.2855
		0.2879	0.2619		0.2960	0.2760
	B5-1	0.2915	0.2855	B5-3	0.2960	0.2760
		0.2870	0.2950		0.2915	0.2855
		0.2970	0.3050		0.3003	0.2950
		0.3003	0.2950		0.3035	0.2850
	B5-2	0.3003	0.2950	B5-4	0.3035	0.2850
		0.2970	0.3050		0.3003	0.2950
		0.3070	0.3150		0.3090	0.3045
		0.3090	0.3045		0.3110	0.2940

Notes:

- 1. The C.I.E. 1931 chromaticity diagram (Tolerance ± 0.01).**

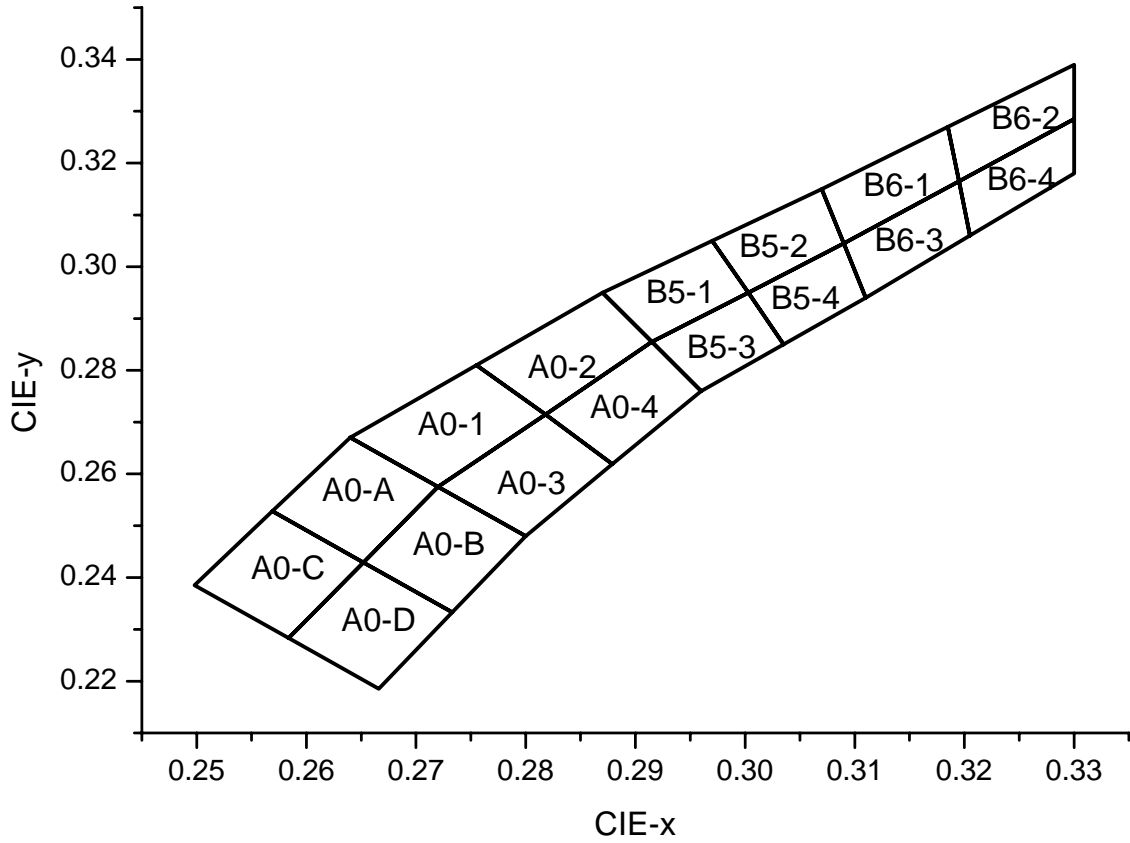

Notes:

- 1. The C.I.E. 1931 chromaticity diagram (Tolerance ± 0.01).**

Typical Electro-Optical Characteristics Curves

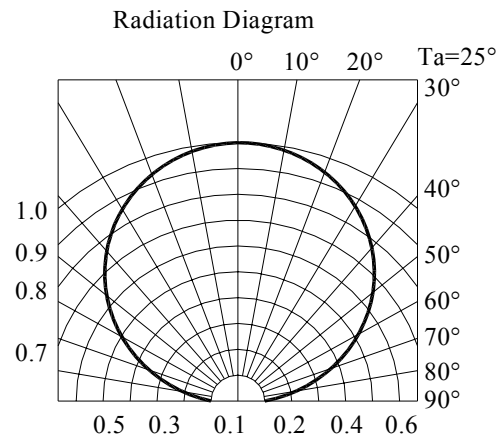
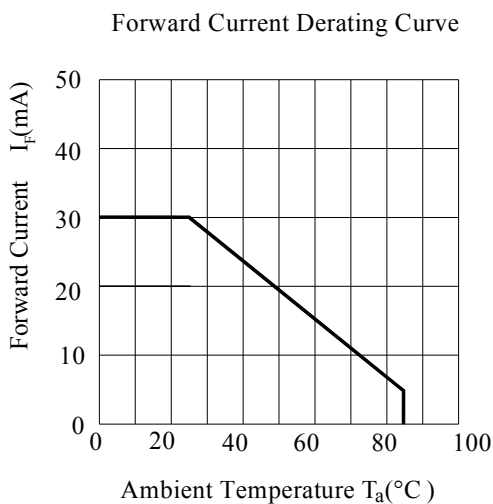
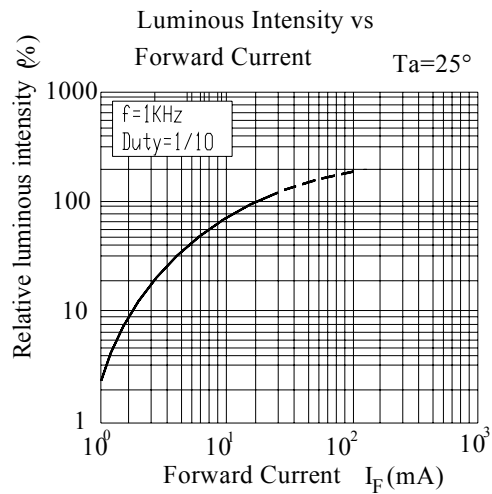
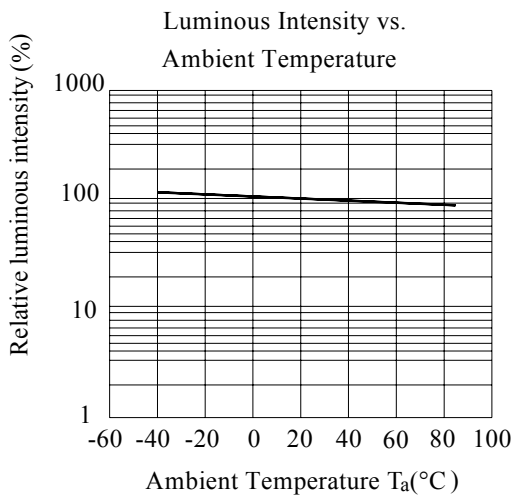
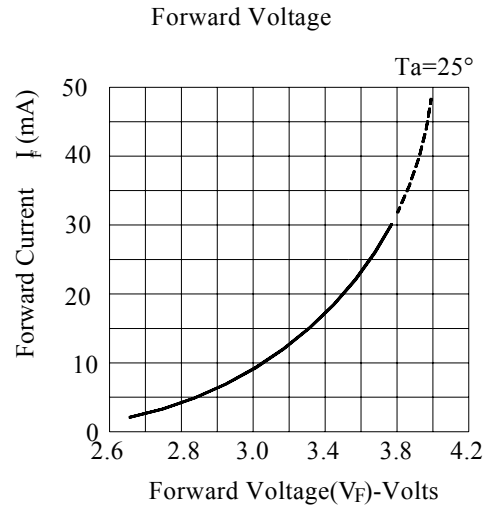
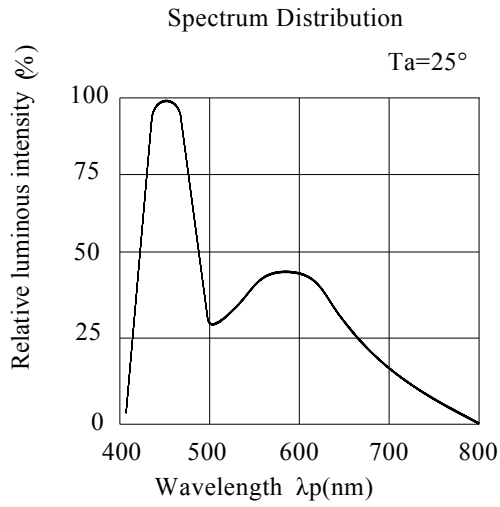

45-21UEC/XXX/TR8

Label explanation

CAT: Luminous Intensity Rank

HUE: Chromaticity Coordinates

REF: Forward Voltage Rank

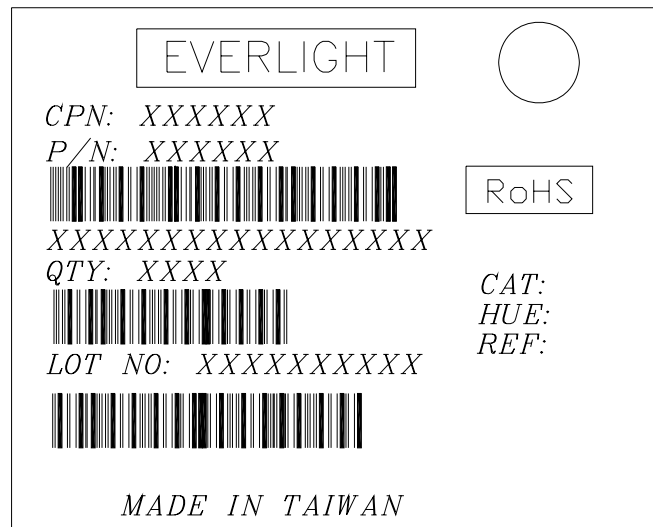

Reel Dimensions

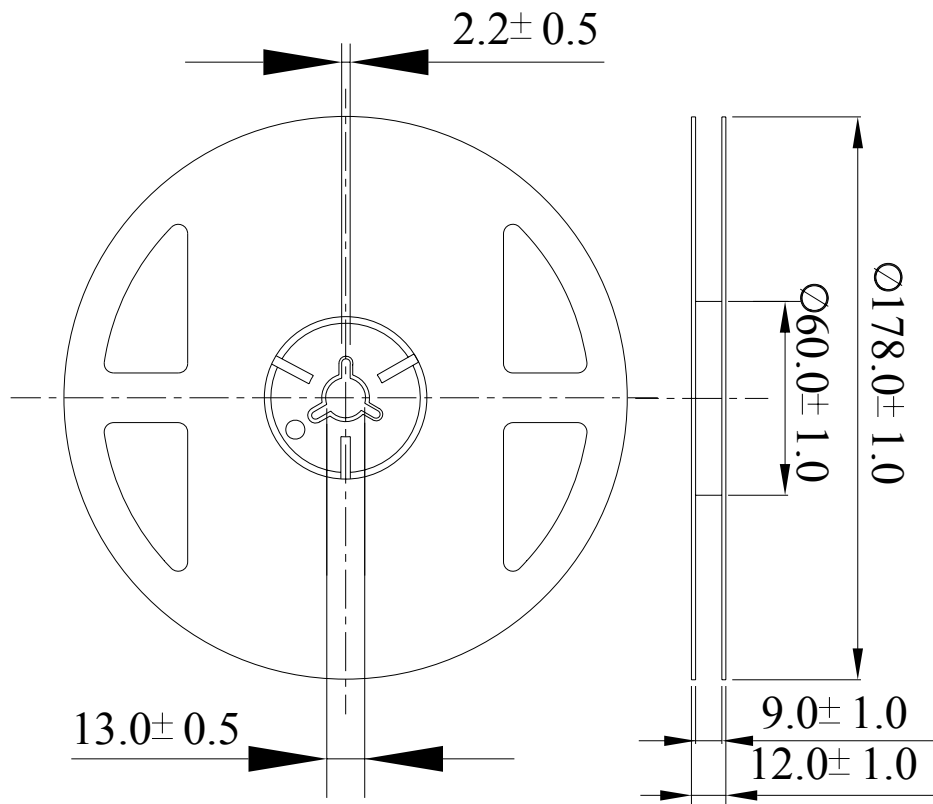

Note : Tolerances unless dimension ±0.1mm. Unit = mm

Carrier Tape Dimensions: Loaded quantity 2000 PCS per reel

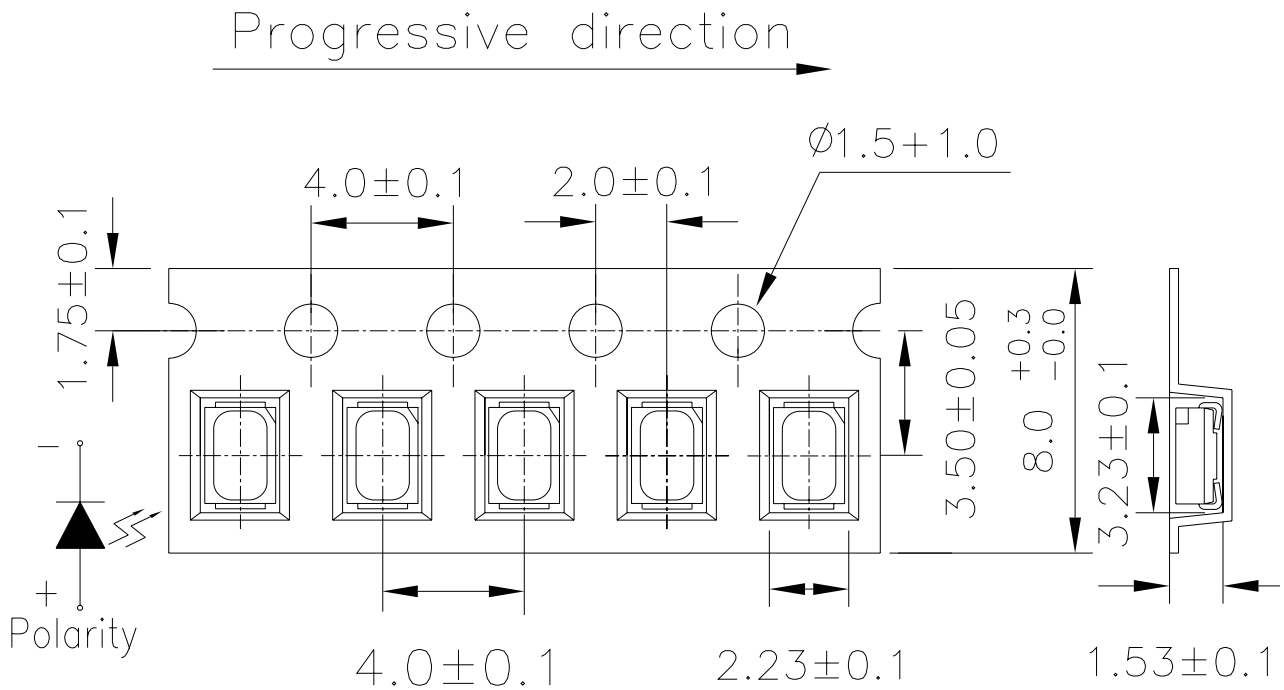

Note : Tolerances unless dimension ± 0.1 mm. Unit = mm

Moisture Resistant Packing

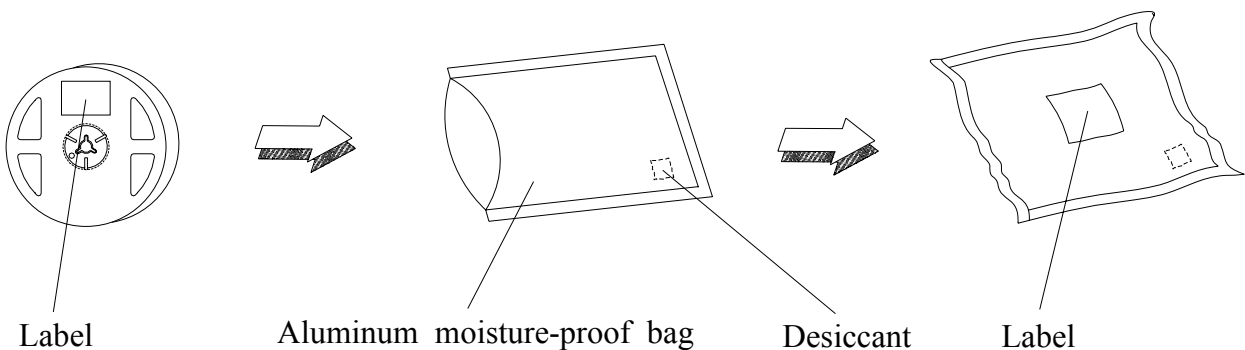

Reliability Test Items and Conditions

The reliability of products shall be satisfied with items listed below.

Confidence level : 90%

LTPD : 10%

No.	Items	Test Condition	Test Hours/Cycles	Sample Size	Ac/Re
1	Reflow Soldering	Temp. : 260°C±5°C Min. 5 sec.	6 Min.	22 PCS	0/1
2	Temperature Cycle	H : +100°C 15min ┆ 5 min L : -40°C 15min	300 Cycles	22 PCS.	0/1
3	Thermal Shock	H : +100°C 5min ┆ 10 sec L : -10°C 5min	300 Cycles	22 PCS.	0/1
4	High Temperature Storage	Temp. : 100°C	1000 Hrs.	22 PCS.	0/1
5	Low Temperature Storage	Temp. : -40°C	1000 Hrs.	22 PCS.	0/1
6	DC Operating Life	I _F = 20 mA / 25°C	1000 Hrs.	22 PCS.	0/1
7	High Temperature / High Humidity	85°C/85%RH	1000 Hrs.	22 PCS.	0/1

Precautions for Use

1. Over-current-proof

Customer must apply resistors for protection, otherwise slight voltage shift will cause big current change (Burn out will happen).

2. Storage

2.1 Do not open moisture proof bag before the products are ready to use.

2.2 Before opening the package: The LED should be kept at 30°C or less and 90%RH or less.

2.3 After opening the package: The LED floor life is 1 year under 30°C or less and 60% RH or less. If unused LED remain, it should be stored in moisture proof packages.

2.4 If the moisture absorbent material (silica gel) has faded away or the LED have exceeded the storage time, baking treatment should be performed using the following conditions.

Baking treatment : 60±5°C for 24 hours.

3. Soldering Condition

3.1 Pb-free solder temperature profile

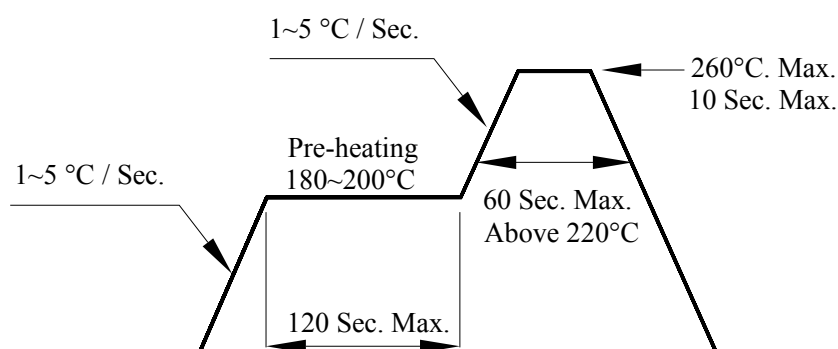

3.2 Reflow soldering should not be done more than two times.

3.3 When soldering, do not put stress on the LEDs during heating.

3.4 After soldering, do not warp the circuit board.

4. Soldering Iron

Each terminal is to go to the tip of soldering iron temperature less than 350°C for 3 seconds within once in less than the soldering iron capacity 25W. Leave two seconds and more intervals, and do soldering of each terminal. Be careful because the damage of the product is often started at the time of the hand solder.

5. Repairing

Repair should not be done after the LEDs have been soldered. When repairing is unavoidable, a double-head soldering iron should be used. It should be confirmed beforehand whether the characteristics of the LEDs will or will not be damaged by repairing.

EVERLIGHT ELECTRONICS CO., LTD.
Office: No 25, Lane 76, Sec 3, Chung Yang Rd,
Tucheng, Taipei 236, Taiwan, R.O.C

Tel: 886-2-2267-2000, 2267-9936
Fax: 886-2267-6244, 2267-6189, 2267-6306
<http://www.everlight.com>